

LED DMX & PWM Dimmer - RGBW User Manual



Item no.: LC-025-004

1. Brief Introduction

Welcome to use the DMX512 Constant Voltage Decoder which is developed only for constant voltage LED lamps. It adopted advanced micro-computer control technology to transfer standard DMX512/1990 signal to PWM signal. user can choose 1~4 output channels, max 3A output each channel, 4096 Grey Scales. It can be used as DMX512 master or as DMX decoder to connect computerized digital output consol with analog silicon case and controls LED lamps of architecture and lighting.

2. Specifications

| | |
|-----------------------|---|
| Input Voltage | 12-24VDC |
| Max. Load Current | 3 channels x 3A (RGB) + 1 channel x 9A (W) |
| Max. Output Power | 3x36W + 1x108W (12V) or 3x72W + 1x216W (24V) |
| Grey Scale | 4096 |
| Input Signal | DMX512/1990 |
| Output Signal | 4xPWM constant voltage with ~980Hz |
| DMX512 Terminal | Terminal Block with max. 2,5mm ² |
| Dimension (L x B x H) | 175 x 46 x 30mm |
| Weight | 160g |

3. Basic Features

1. Automatically adapt input voltage DC12V-24V.
2. Input standard DMX512 signal; 3-digital-display tube shows DMX address code..
3. 4 channels output; 4096 grey scales each; logarithmic dimming; lamplight soft& stable without strobe flash.
4. DMX Master mode, Slave mode available.
5. 8 color changing modes and 10 speed scales in master mode .
6. Indicator of the DMX512 signal receiving status.
7. Over current protection and short circuit protection.
8. Power loss memory function.

4. Safety warnings

1. To ensure your safety and product properly usage, please read the user manual carefully.
2. To avoid installed the product in minefield, strong magnetic field and high voltage area.
3. To ensure the wiring is correct and firm avoiding short circuit damages to components and cause fire.
4. Please install the product in a well ventilated area to ensure appropriate temperature environment.
5. The product must be worked with DC constant voltage power supply.
Please check the consistence of input power with the product, if the output voltage of the power comply with that of the product.
6. Connect the wire with the power on is forbidden. Ensure proper wiring first then check to ensure no short-circuit, then power on !
7. Don't repair it by yourself whenever an error occur. Contact the supplier for any inquiry.

5. Dimensions

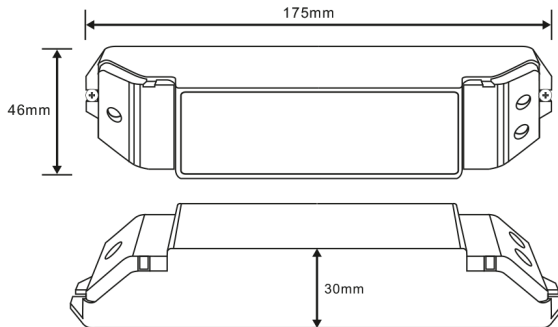

6. Operating instructions

Three touch buttons: S,+,-

| | |
|---|--|
| S | change the turns in the 3 display tube |
| + | increase |
| - | decrease |

Three-digital-display tube indicates the current setting value; different value indicates different operating status. The digital tubes goes off without operation for 5 minutes, press any key to turn it on. When it is overload or short-circuits, the decoder will automatically stop output, LED display twinkles and shows: "ERR" , as below:



1. DMX Slave Mode: The value is: 001-512, such as: "001"



The decimal point of last digital of the display tube will twinkle regularly when receives DMX512 signal normally.
When no signal is received, the decimal point does not twinkle, and showing current DMX address.

2. DMX Slave Modus and PWM Dimmable Modus:

| | |
|---------|--|
| 000 | All 4 channels RGB on 100% |
| 513 | Static red |
| 514 | Static green |
| 515 | Static blue |
| 516 | Static purple |
| 517 | Static cyan |
| 518 | Static yellow |
| 519 | Static orange |
| 520-529 | Colour skipping 1 (red - orange- yellow - green - cyan - blue - purple) |
| 530-539 | Colour skipping 2 (white - purple -red- orange - yellow - green - cyan - blue) |
| 540-549 | Colour skipping 1 (amber- red) |
| 550-559 | Colour skipping 1 (purple - blue) |
| 560-569 | Colour skipping 1 (cyan - blue) |
| 570-579 | Colour skipping 1 (green - yellow) |
| 580-589 | Pulsating up and down of all 4 channels simultaneously between 1 and 100% |
| 590-599 | Strobo of all 4 channels simultaneously between 1 and 100% |
| 600-699 | Dimmable Modus for channel red between 0-99% |
| 700-799 | Dimmable Modus for channel green between 0-99% |
| 800-899 | Dimmable Modus for channel blue between 0-99% |
| 900-999 | Dimmable Modus for channel white between 0-99% |



RGB three color skipping Speed level 4

Between 520-599 die first and second decimal point show the programme and the third decimal point shows the speed.

For the programmes 520-589 apply following speed adjustments for one programme step:
 0 = 0,5 sec. | 1 = 1 sec. | 2 = 2 sec. | 3 = 3 sec. | 4 = 5 sec. | 5 = 10 sec. | 6 = 15 sec. | 7 = 30 sec.
 8 = 60 sec. | 9 = 120 sec.

For the programme 590-599 apply following speed adjustments for one programme step:
 0 = 0,02 sec. | 1 = 0,04 sec. | 2 = 0,1 sec. | 3 = 0,2 sec. | 4 = 0,5 sec. | 5 = 1 sec. | 6 = 2 sec.
 7 = 5 sec. | 8 = 10 sec. | 9 = 15 sec.

Between 600-999 the first decimal point shows the requested channel R = 6, G = 7, B = 8, W = 9, the second and third decimal point show the dimmable value between 0-99%.

7. Exception Handles

| Malfunction | Reasons | Solutions |
|--|--|--|
| No light | 1. no power supply | 1. Check power supply |
| | 2. Reversed polarity | 2. Reverse it |
| | 3. Signal terminal not connected or reversed | 3. Signal terminal not connected or reversed |
| | 4. Long circuit such as longer than 300m | 4. Add signal terminator or amplifier |
| Wrong color | 5. RGBW wrong wiring | 5. Re-wire RGBW |
| | 6. Wrong input of decoder address | 6. Re-input |
| One or several color(s) alight but no change | 7. Signal terminator wrongly connected or reversed | 7. Check the wiring re-wire it properly |
| | 8. Long circuit such as longer than 300m | 8. Add signal terminator or amplifier |
| Abnormal shake during | 9. Signal terminator not be properly connected | 9. Connect it properly |
| | 10. Long circuit such as longer than 300m | 10. Add DMX signal transmitter or splitter |

8. Conjunction Diagram

1) Wiring diagram of Master Mode: (Only one decoder is allowed to work as a master)

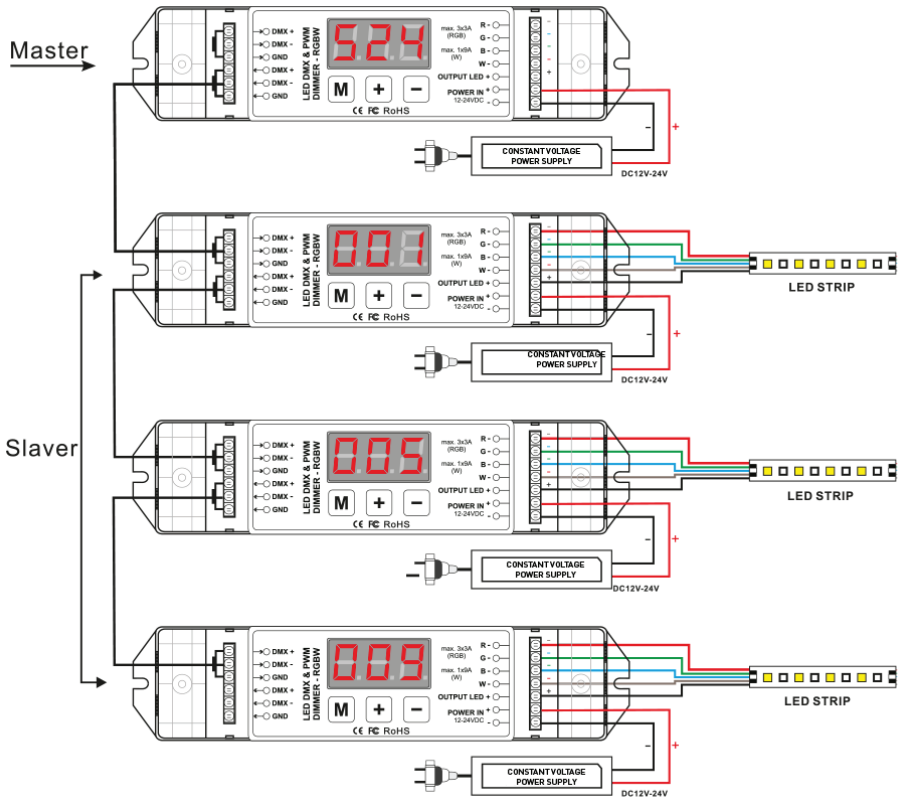

2) Wiring diagram of Slave Mode:

