

LED DMX & PWM Dimmer - Mono User Manual



Item no.: LC-025-001

1. Brief Introduction

Welcome to use the DMX512 Constant Voltage Decoder which is developed only for constant voltage LED lamps. It adopted advanced micro-computer control technology to transfer standard DMX512/1990 signal to PWM signal. one channel output,max 10A output each channel, 4096 Grey Scales. It can be used as DMX512 master or as DMX decoder to connect computerized digital output consol with analog silicon case and controls LED lamps of architecture and lighting.

2. Specifications

Input Voltage	12-24VDC
Max. Load Current	1 channel x 10A
Max. Output Power	1x120W (12V) or 1x240W (24V)
Grey Scale	4096
Input Signal	DMX512/1990
Output Signal	1xPWM constant voltage with ~980Hz
DMX512 Terminal	Terminal Block with max. 2,5mm ²
Dimension (L x B x H)	175 x 46 x 30mm
Weight	150g

3. Basic Features

1. Automatically adapt input voltage DC5V-24V.
2. Input standard DMX512 signal; 3-digital-display tube shows DMX address code..
3. 1 channels output; 4096 grey scales each; logarithmic dimming; lamplight soft& stable without strobe flash.
4. DMX Master mode, Slave mode available.
5. 12 color changing modes and 10 speed scales in master mode .
6. Indicator of the DMX512 signal receiving status.
7. Over current protection and short circuit protection.
8. Power loss memory function.

4. Safety warnings

1. To ensure your safety and product properly usage, please read the user manual carefully.
2. To avoid installed the product in minefield, strong magnetic field and high voltage area.
3. To ensure the wiring is correct and firm avoiding short circuit damages to components and cause fire.
4. Please install the product in a well ventilated area to ensure appropriate temperature environment.
5. The product must be worked with DC constant voltage power supply.
Please check the consistence of input power with the product, if the output voltage of the power comply with that of the product.
6. Connect the wire with the power on is forbidden. Ensure proper wiring first then check to ensure no short-circuit, then power on !
7. Don't repair it by yourself whenever an error occur. Contact the supplier for any inquiry.

5. Dimensions

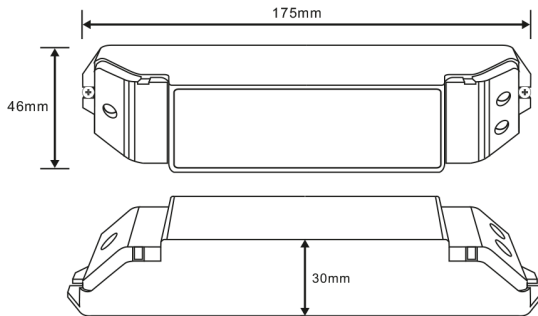

6. Operating instructions

Three touch buttons: M, +, -

M	change the turns in the 3 display tube
+	increase
-	decrease

Three-digital-display tube indicates the current setting value; different value indicates different operating status. The digital tubes goes off without operation for 1 minute , press any key to turn it on. When it is overload or short-circuits, the decoder will automatically stop output, LED display twinkles and shows: "ERR" , as below:



1. DMX Slave Mode: The value is: 001-512, such as: "001"



The decimal point of last digital of the display tube will twinkle regularly when receives DMX512 signal normally.

When no signal is received, the decimal point does not twinkle, and showing current DMX address.

2. DMX Slave Modus:

000	100% light intensity
600-699	Dimmable mode for the output signal between 0-99%
700-709	Pulsating up and down dimming between 0% und 100%
710-719	Pulsating up and down dimming between 1% und 100%
720-729	Pulsating up and down dimming between 5% und 100%
730-739	Pulsating up and down dimming between 10% und 100%
740-749	Pulsating up and down dimming between 15% und 100%
750-759	Pulsating up and down dimming between 20% und 100%
760-769	Pulsating up and down dimming between 30% und 100%
770-779	Pulsating up and down dimming between 40% und 100%
780-789	Pulsating up and down dimming between 50% und 100%
790-799	Pulsating up and down dimming between 60% und 100%
800-809	Strobe between 0% und 100%
810-819	Strobe between 1% und 100%
820-829	Strobe between 5% und 100%
830-839	Strobe between 10% und 100%
840-849	Strobe between 15% und 100%
850-859	Strobe between 20% und 100%
860-869	Strobe between 30% und 100%
870-879	Strobe between 40% und 100%
880-889	Strobe between 50% und 100%
890-899	Strobe between 60% und 100%
900-909	Dimming up and switch between 0% and 100%
910-919	Dimming up and switch between 1% and 100%
920-929	Dimming up and switch between 5% and 100%
930-939	Dimming up and switch between 10% and 100%
940-949	Dimming up and switch between 15% and 100%
950-959	Dimming up and switch between 20% and 100%
960-969	Dimming up and switch between 30% and 100%
970-979	Dimming up and switch between 40% and 100%
980-989	Dimming up and switch between 50% and 100%
990-999	Dimming up and switch between 60% and 100%



Between 700-999 die first and secon decimal point show the programme and the third decimal point shows the speed.

For the programmes 700-799 and 900-999 apply following speed adjustments for one programme step: 0 = 0,5 sec. | 1 = 1 sec. | 2 = 2 sec. | 3 = 5 sec. | 4 = 10 sec. | 5 = 15 sec. | 6 = 20 sec. | 7 = 30 sec. | 8 = 60 sec. | 9 = 90 sec.

For the programmes 800-899 apply following speed adjustments for one programme step: 0 = 0,02 sec. | 1 = 0,04 sec. | 2 = 0,1 sec. | 3 = 0,2 sec. | 4 = 0,5 sec. | 5 = 1 sec. | 6 = 2 sec. | 7 = 5 sec. | 8 = 10 sec. | 9 = 15 sec.

Between 600-699 the first and the second decimal point together show the dimmed value between 0-99%.

7. Exception Handles

Malfunction	Reasons	Solutions
No light	1. no power supply	1. Check power supply
	2. Reversed polarity	2. Reverse it
	3. Signal terminal not connected or reversed	3. Signal terminal not connected or reversed
	4. Long circuit such as longer than 300m	4. Add signal terminator or amplifier
One or several color(s) alight but no change	5. Signal terminator wrongly connected or reversed	5. Check the wiring re-wire it properly
	6. Long circuit such as longer than 300m	6. Add signal terminator or amplifier
Abnormal shake during	7. Signal terminator not be properly connected	7. Connect it properly
	8. Long circuit such as longer than 300m	8. Add DMX signal transmitter or splitter

8. Conjunction Diagram

1) Wiring diagram of Master Mode: (Only one decoder is allowed to work as a master)

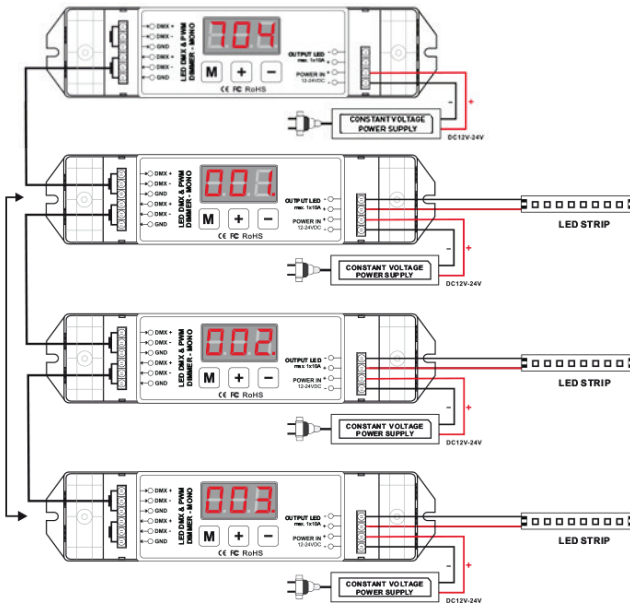

2) Wiring diagram of Slave Mode:

